

Steca PF 166-H | PF 240-H

Solar refrigerator/freezer

Steca PF refrigerators are some of the most efficient DC energy-saving refrigerators ever developed. Now filled with an even more climate-friendly refrigerant, they can be used as either a refrigerator or a freezer.

The Steca PF 166-H and Steca PF 240-H are fully programmable. The inside temperature and each of the other configuration values can be set by the user. They are therefore perfectly suited for all DC applications including even the refrigeration of medicines in hospitals. The optimal electronic control and speed regulation of the compressor guarantees extremely efficient use of energy. This leads to significant cost reductions.

This product stands out for its user-friendliness, thanks to a large digital display with setting options, the highest standards of quality and reliability, energy efficient interior LED lamp and a long service life. The refrigerator or freezer is easy to clean as it has a sealing plug on the bottom for draining water.



Product features

- Fast and efficient cooling due to compressor speed control
- The freezers can be operated via an off-grid battery system with a 70 w photovoltaic module in most climates
- Automatic detection of voltage
- Temperature fully programmable
- Adjustable refrigerator or freezer function
- Suitable for all DC applications
- Low maintenance and easy to clean
- Lock with two keys
- Also suitable for mobile use
- Auto-dimming for reduction of own consumption
- Climate-friendly refrigerant
- Energy-efficient LED interior lamp

Electronic protection functions

- Reverse polarity protection
- Deep discharge protection
- Power breakdown display
- Temperature alarm

Displays

- Multifunction LED display
- Digital temperature display

Operation

- Programming by buttons

Certificates

- Compliant with European Standards (CE)
- RoHS compliant
- Abstinance of ozone destroying materials according EC 1005/2009 (CFC-free)
- Made in EU
- Manufactured according to ISO 9001 and ISO 14001

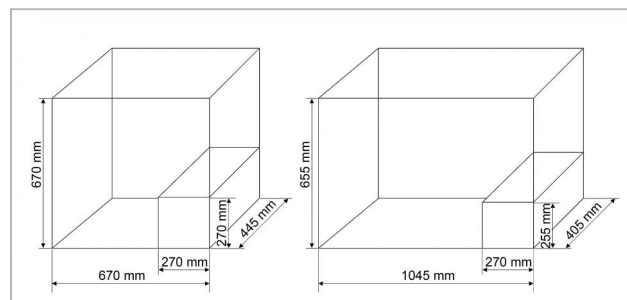

Consumption Steca PF 166-H [Wh / day]		
Ambient temperature	25 °C	40 °C
Interior temperature +8 °C	87	232
Interior temperature +3 °C	113	303
Interior temperature -10 °C	277	624
Interior temperature -20 °C	525	1215
Consumption Steca PF 240-H [Wh / day]		
Ambient temperature	25 °C	40 °C
Interior temperature +8 °C	93	266
Interior temperature +3 °C	136	361
Interior temperature -10 °C	370	878
Interior temperature -20 °C	764	1794

	PF 166-H	PF 240-H
Characterisation of the operating performance		
System voltage	12 V (24 V)	
Nominal power	50 W ... 72 W	
Cooling volume (net)	166 litres	240 litres
Refrigerator temperature	+2 °C ... +12 °C	
Freezer temperature	-20 °C ... -10 °C	
DC input side		
Input voltage	10 V ... 17 V (17 V ... 31.5 V) 12 V / 24 V battery	
DC output side		
Reconnection voltage (LVR)	11.7 V (24.2 V)	
Deep discharge protection (LVD)	10.4 V (22.8 V)	
Operating conditions		
Ambient temperature	+10 °C ... +43 °C	
Fitting and construction		
Dimensions (X x Y x Z)	872 x 917 x 709 mm	1288 x 919 x 760 mm
Insulation strenght	11 cm	12 cm
Weight	47 kg	62 kg
Cooling principle	compressor	
Refrigerant	60 g R290	70 g R290
Celsius / Fahrenheit temperature display	adjustable	
Display brightness	adjustable	
Hanging baskets	2	
Freezer trays	3	
Cold battery	1	
Automatic energy-saving mode	yes	

Bur Dubai Office:

Showroom # 19, SUQ Al Kabeer Building,
Bur Dubai, Dubai, UAE

Deira Office:

Showroom # 5 & 6, 7 States Building
Baniyas Square, Deira, Dubai, UAE